

## MOTORIZED PULLEYS FOR BELT CONVEYORS BULK HANDLING

GENERAL CATALOGUE

**Moving ahead.**





## OPTIONAL EXTRAS

### Motorized Pulley 320L, 320M & 320H

Specification	320L	320M & 320H
Total stainless steel option AISI 304 range TS9N Re-greasable labyrinth seals!	x	x
Total stainless steel option AISI 304 range TS10N Standard seals!	x	x
Semi-rust-free option TS11N Re-greasable labyrinth seals!	x	x
Semi-rust-free option TS12N Standard seals!	x	x
Food grade oil & grease - FDA & USDA recognized - available on request	x	x
Dust explosion proof Motorized Pulleys - ATEX 95 - Zone 22 - for applications handling of dusty grain etc. According to European Directive 94/9/EC.	On request!	On request!
TOTAL acid resistant stainless steel option - AISI 316	x	x
Re-greasable labyrinth seals - mild steel	x	x
Black rubber lagging - STANDARD specifications: - Smooth lagging - Hardness 60 ±5 Shore A - Diamond lagging - Hardness 60 ±5 Shore A	o 5/8 mm 6/8 mm	o 5/8 mm 6/8 mm
White smooth rubber lagging (FDA). Oil, fat & grease resistant	x	x
SPECIAL lagging available on request - e.g. hot vulcanized, ceramic etc.	x	x
Electromagnetic brake	x	x
Min. RL dimensions increases by (mm)	100	100
Mechanical backstop	x	x
Min. RL dimensions increases by (mm)		50
Modified for vertical mounting	o	o
Modified for mounting between 5° - ≤ 90° - e.g. for magnetic separators	o	o
Insulation class F - Allowable ambient temperature: -25°C-+40°C	Std.	Std.
Insulation class H with synthetic oil	x	x
SPECIAL motors for applications with NO belt contact	x	x
Low noise drives for noise sensitive areas	x	x
Parallel shell	x	x
Thermal protector	Std.	Std.
IP66/67 Compact powder coated aluminium terminal box - food grade approved	Std.	Std. ≤ 4.0 kW
IP66/67 Compact stainless steel - AISI 304 or 316 range - terminal box	x	≤ 4.0 kW
IP66/67 Larger powder coated aluminium terminal box - food grade approved		Std. ≥ 5.5 kW
Straight or elbow connector with flying lead	x	≤ 4.0 kW
Straight connector with flying lead - Stainless steel - AISI 304 range -	x	≤ 4.0 kW
Shaft sealing system - degree of protection IP66/67 (EN60034-5)	Std.	Std.
Screened cables - a MUST together with Frequency Converters	x	x
3-phase single voltage (3 x 400V) or (3 x 690V) 50Hz +/- 10% - DIN IEC 38	Std.	Std.
Euro wide range voltage (3 x 380-415V 50 Hz) with +/-10% tolerance - DIN IEC 38 or (3 x 660-690V 50 Hz)	x	x
Special voltages - 50 and/or 60 Hz Please specify!	x	x
Dual voltage - delta/star - connection!	x	x
CSA approved motors - available on request only!	x	x

**x** = Optional extra's

**o** = An option with certain limitations. Please refer to Technical precautions pages 81-92!

**Std.** = Fitted as standard

# Motorized Pulley 320L, 320M & 320H, Ø 320 mm

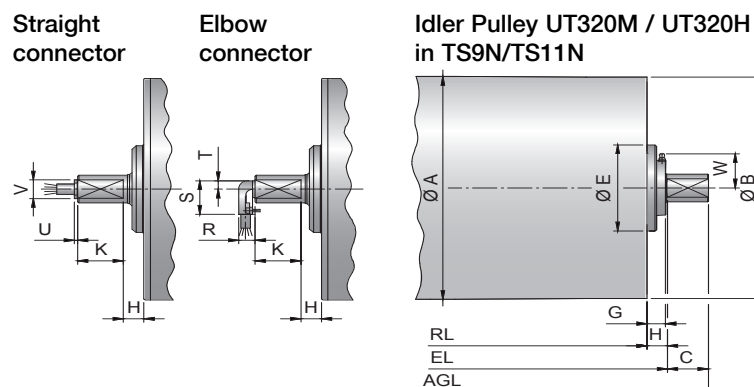
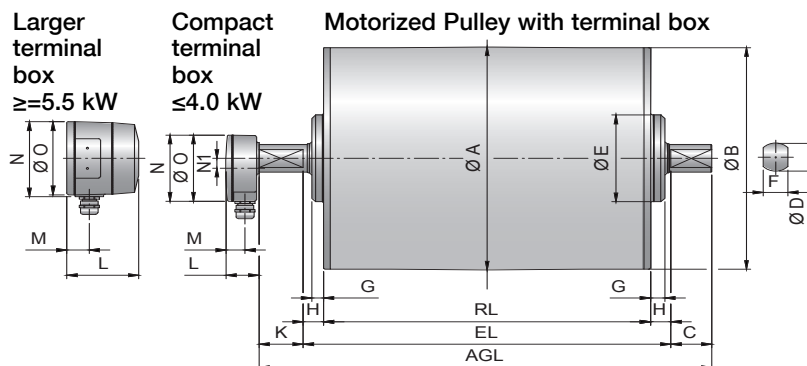

Type	Motorized Pulley or idler Pulley (UT)											Compact terminal box ≤4.0 kW				Larger terminal box ≥5.5 kW				Straight connector ≤4.0 kW		Elbow connector ≤4.0 kW		
	A	B	C	D	E	F	G	G	TS9/11	H	K	W	L	M	N	N1	L	M	N	O	U	V	R	S
	mm	mm	mm	mm	mm	mm	mm	mm	mm	mm	mm	mm	mm	mm	mm	mm	mm	mm	mm	mm	mm	mm	mm	mm
320L	323	319	50	40	96	30	15	19.5	25	54	-	41	24	95	14	-	-	-	-	4	27	20	48	12
320M	321	319	50	40	125	30	17.5	22.5	25	54	-	41	24	95	14	87	27	107	105	4	27	20	48	12
320H	321	319	50	50	148	40	11	20.5	25	54	-	41	24	95	14	87	27	107	105	4	27	20	48	12
UT320M	321	319	50	40	125	30	14.5	22.5	25	-	52	→ Idler Pulley shown in TS9N/TS11N version with re-greasable seals												
UT320H	321	319	50	50	148	40	11	20.5	25	-	52	→ Idler Pulley shown in TS9N/TS11N version with re-greasable seals												

## Mounting brackets KL41-HD & KL42

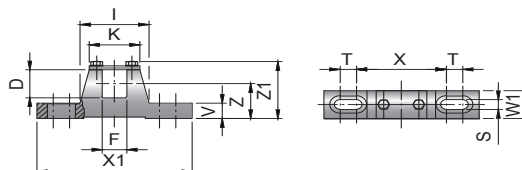

Motorized Pulleys Type	Material	Bracket description	Dimensions												Weight kg
			D	F	I	K	S	T	V	W1	X	X1	Z	Z1	
			mm	mm	mm	mm	mm	mm	mm	mm	mm	mm	mm	mm	mm
320L & 320M	Steel	KL41-HD	40	30	84	62	14	20	22	40	110	190	50	83	2.1
320H	Steel	KL42	50	40	121	90	18	30	25	50	150	250	70	110	4.5



## Motorized Pulley 320L, Ø 320 mm

50 Hz

Motor			Nominal belt speed at Full Load 50Hz m/sec	Torque Nm	Belt Pull N	Max. Radial Load T1+T2 N	Special min. RL	Type	Weight in kg for STANDARD width											Type of Bracket
Power kW/HP	No. of Poles	Gear stages							Dimension RL in mm (RL >2000 mm available on request)											
									400	450	500	550	600	650	700	750	800	850	per 50 mm up to 2000	
0.75/1.00	8	2	0.32	356	2218	11500	450	320L	78	82	86	90	94	98	102	106	110	4 kg	KL41-HD	
			0.40	285	1776															
			0.50	228	1421															
			0.63	181	1128															
			0.80	142	885															
			1.00	114	710															
			1.25	92	573															
1.10/1.50	4	2	0.63	265	1651	11500	400	320L	73	76	80	84	88	92	96	100	104	108	4 kg	KL41-HD
			0.80	209	1302															
			1.00	167	1040															
			1.25	134	835															
			1.60	105	654															
			2.00	84	524															
			2.50	67	417															
1.50/2.00	4	2	0.63	362	2255	11500	400	320L	75	78	82	86	90	94	98	102	106	110	4 kg	KL41-HD
			0.80	285	1776															
			1.00	228	1421															
			1.25	182	1134															
			1.60	143	891															
			2.00	114	710															
			2.50	92	573															
2.20/3.00	4	2	0.80	418	2604	11500	450	320L	82	86	90	94	98	102	106	110	114	4 kg	KL41-HD	
			1.00	334	2081															
			1.25	265	1651															
			1.60	209	1302															
			2.00	167	1040															
			2.50	134	835															
			3.00/4.00	4	2															1.25
1.60	285	1776																		
2.00	228	1421																		
2.50	182	1134																		
2.50	182	1134																		
4.00/5.50	2	2	1.60	380	2368	11500	500	320L	90	94	98	102	106	110	114	118	4kg	KL41-HD		
			2.00	304	1894															
			2.50	243	1514															

## Motorized Pulley 320M & 320H, Ø 320 mm

50 Hz

Motor			Nominal belt speed at Full Load 50Hz m/sec	Torque Nm	Belt Pull N	Max. Radial Load T1+T2 N	Special min. RL	Type	Weight in kg for STANDARD width											Type of Bracket
Power kW/HP	No. of Poles	Gear stages							Dimension RL in mm (RL >2000 mm available on request)											
									450	500	550	600	650	700	750	800	850	per 50 mm up to 2000		
0.75/1.00	12	3	0.13	876	5475	35000	550	320H	135	139	144	149	154	159	164	5 kg	KL42-HD			
			0.16	712	4453															
			0.20	570	3562															
				2	0.25	456	2841	20000	500	320M	110	114	118	122	126	130	134	138	4 kg	KL41-HD
					0.32	356	2218													
					0.40	285	1776													
					0.50	228	1421													
1.10/1.50	12	3	0.13	1286	8039	35000	550	320H	135	139	144	149	154	159	164	5 kg	KL42-HD			
			0.16	1045	6531															
		0.20	836	5225																
		0.25	669	4181																
		0.32	522	3252																
		8	2	0.40	418	2604	20000	500	320M	110	114	118	122	126	130	134	138	4 kg	KL41-HD	
				0.50	334	2081														
				0.63	265	1651														
				0.80	209	1302														
				1.00	167	1040														
				1.25	134	835														

Idler Pulley	20000	450	UT320M	50	54	58	62	66	70	74	78	82	4 kg	KL41-HD
		35000	450	UT320H	50	61	65	69	73	77	81	85	89	4 kg



# Motorized Pulley 320M & 320H, Ø 320 mm

# 50 Hz

Power kW/HP	Motor		Nominal belt speed at Full Load 50Hz m/sec	Torque Nm	Belt Pull N	Max. Radial Load T1+T2 N	Special min. RL	Type	Weight in kg for STANDARD width											Type of Bracket
	No. of Poles	Gear stages							Dimension RL in mm (RL >2000 mm available on request)											
									450	500	550	600	650	700	750	800	850	per 50 mm up to 2000		
1.50/ 2.00	8	3	0.16	1425	8906	35000	550	320H	[shaded]	[shaded]	135	139	144	149	154	159	164	5 kg	KL42-HD	
			0.20	1140	7125															
		0.25	912	5700																
	1.50/ 2.00	8	2	0.32	712	4436	20000	500	320M	[shaded]	110	114	118	122	126	130	134	138	4 kg	KL41-HD
				0.40	570	3551														
				0.50	456	2841														
				0.63	362	2255														
0.80				285	1776															
1.00				228	1421															
1.25				182	1134															
2.20/ 3.00	8	3	0.20	1672	10450	35000	550	320H	[shaded]	[shaded]	135	139	144	149	154	159	164	5 kg	KL42-HD	
			0.25	1338	8362															
		0.32	1045	6531																
	2.20/ 3.00	8	2	0.40	836	5225	20000	500	320M	[shaded]	110	114	118	122	126	130	134	138	4 kg	KL41-HD
				0.50	669	4181														
				0.63	522	3252														
				0.80	418	2604														
1.00				334	2081															
1.25				265	1651															
1.60				209	1302															
3.00/ 4.00	6	3	0.25	1824	11400	35000	550	320H	[shaded]	[shaded]	135	139	144	149	154	159	164	5 kg	KL42-HD	
			0.32	1425	8906															
			0.40	1140	7125															
	3.00/ 4.00	6	3	0.50	912	5700	20000	500	320M	[shaded]	100	104	108	112	116	120	124	128	4 kg	KL41-HD
				0.63	727	4525														
				0.80	570	3562														
				1.00	456	2841														
1.25				362	2255															
1.60				285	1776															
2.00				228	1421															
2.50	182	1134																		
4.00/ 5.50	6	3	0.32	1900	11875	35000	550	320H	[shaded]	[shaded]	135	139	144	149	154	159	164	5 kg	KL42-HD	
			0.40	1520	9499															
			0.50	1216	7600															
	4.00/ 5.50	6	3	0.63	965	6031	20000	500	320M	[shaded]	110	114	118	122	126	130	134	138	4 kg	KL41-HD
				0.80	760	4735														
				1.00	608	3788														
				1.25	486	3028														
1.60				380	2368															
2.00				304	1894															
2.50				243	1514															
5.50/ 7.50	4	3	0.40	2090	13062	35000	550	320H	[shaded]	[shaded]	135	139	144	149	154	159	164	5 kg	KL42-HD	
			0.50	1672	10450															
			0.63	1327	8294															
	5.50/ 7.50	4	3	0.80	1045	6531	20000	500	320M	[shaded]	110	114	118	122	126	130	134	138	4 kg	KL41-HD
				1.00	836	5225														
				1.25	671	4180														
				1.60	524	3259														
2.00				418	2604															
2.50				334	2081															
7.50/ 10.00				2	3	0.80														
	1.00	1140	7125																	
	1.25	911	5700																	
	7.50/ 10.00	2	2	1.60	712	4453	20000	500	320M	[shaded]	110	114	118	144	149	154	159	164	4 kg	KL41-HD
				2.00	570	3562														
				2.50	456	2850														
				1.00	1672	10450														
11.00/ 15.00	2	3	1.25	1327	8294	35000	1100	320H	[shaded]	Note for: 11kW: min. RL 1100							178	182	5 kg	KL42-HD
			1.60	1045	6531															
			2.00	836	5225															
			2.50	671	4180															
			2.00	570	3562															

Idler Pulley	20000	450	UT320M	50	54	58	62	66	70	74	78	82	4 kg	KL41-HD
		35000	450	UT320H	57	61	65	69	73	77	81	85	89	4 kg

# Motorized Pulley 320L, Ø 320 mm

## Spare parts list and sectional drawings

Pos.	Description	Pos.	Description	Pos.	Description
1	Shell	24	2 Dust lip seals each side	78	Gasket
2	End housing with geared rim	24	1 Double lip seal for labyrinth option	79	Holding clip or plastic tie
3	End housing	25	O-ring	85.1	Intermediate flange for brake assembly
8	Geared rim	26	Bearing	91	Electromagnetic brake
9	Rotor pinion	27	Bearing	93	Retaining ring
10	Input wheel	28	Bearing	95	Straight connector
11	Output pinion	29	Bearing (Backstop solution: One-way-bearing)	96	Elbow connector
12	Gear box	30	Bearing	101	Key
13	Front shaft	31	Bearing	104	Distance washer
14	Rear shaft	39	Hexagon socket screw	120	Labyrinth cover
15	Stator complete	40	Hexagon socket screw	121	Set screw
15.1	Rotor	52	Magnetic oil plug	122	O-ring
16	Terminal box complete	53	Distance washer	123	Grease nipple
17	Nipple	53.1	Compression nipple	124	Washer
20	Cover	59	Countersunk head screw	143	O-ring
20.1	Cover with labyrinth groove	66	Waved spring washer	146	Special shaped compression washer
23	Rear flange	68	Key	200	Rubber seal
23.1	Rear flange for backstop	70	Toothed washer	202	Motor data plate
23.2	Rear flange for electromagnetic brake				

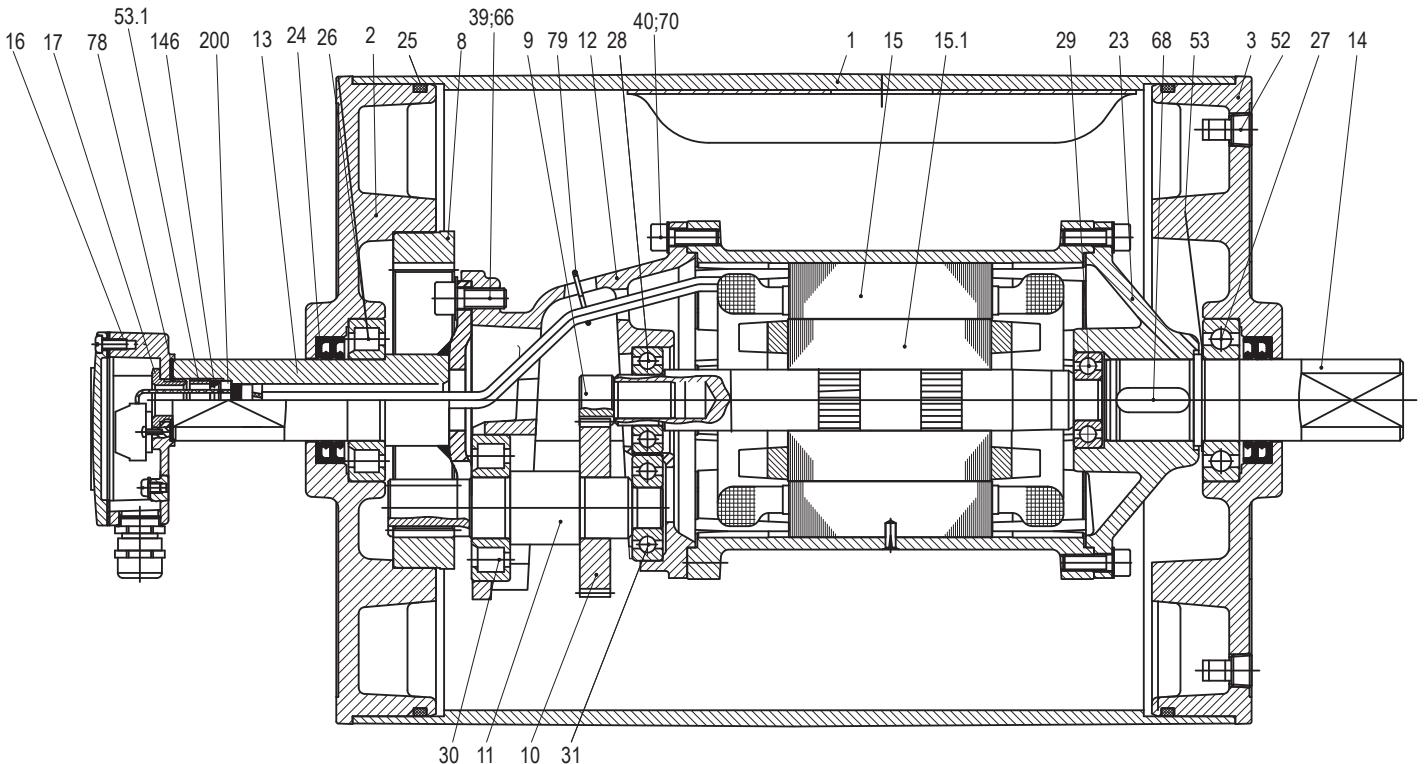



# Motorized Pulley 320M, Ø 320 mm

## Spare parts list and sectional drawings

Pos.	Description	Pos.	Description	Pos.	Description
1	Shell	28	Bearing	70	Toothed washer
2	End housing with geared rim	29	Bearing	75	Gasket
3	End housing	30	Bearing	78	Gasket
8	Geared rim	30	Bearing	79	Holding clip or plastic tie
9	Rotor pinion	31	Bearing	81	Rotor pinion shaft
10	Input wheel	32	Retaining ring	85	Intermediate flange for backstop
11	Output pinion	33	Retaining ring	85.1	Intermediate flange for brake assembly
12	Gear box	35	Retaining ring	90	Backstop
13	Front shaft	37	Hexagon head screw	91	Electromagnetic brake
14	Rear shaft	43	Hexagon head screw	93	Retaining ring
15	Stator complete	44	Hexagon head screw	94	Hexagon head screw
15.1	Rotor	45	Hexagon head screw	95	Straight connector
16	Terminal box complete	46	Hexagon head screw	96	Elbow connector
17	Nipple	52	Magnetic oil plug	99	Waved spring washer
20	Cover	53	Distance washer	101	Key
20.1	Cover with labyrinth groove	53.1	Compression nipple	104	Distance washer
23	Rear flange	60	Parallel pin	120	Labyrinth cover
23.1	Rear flange for backstop/Brake	64	Prevailing torque type hexagon nut	121	Set screw
24	2 Dust lip seals each side	66	Waved spring washer	122	O-ring
25	O-ring	67	Toothed washer	123	Grease nipple
26	Bearing	68	Key	143	O-ring
27	Bearing	69	Key	146	Special shaped compression washer
				200	Rubber seal
				230	Deflection seal

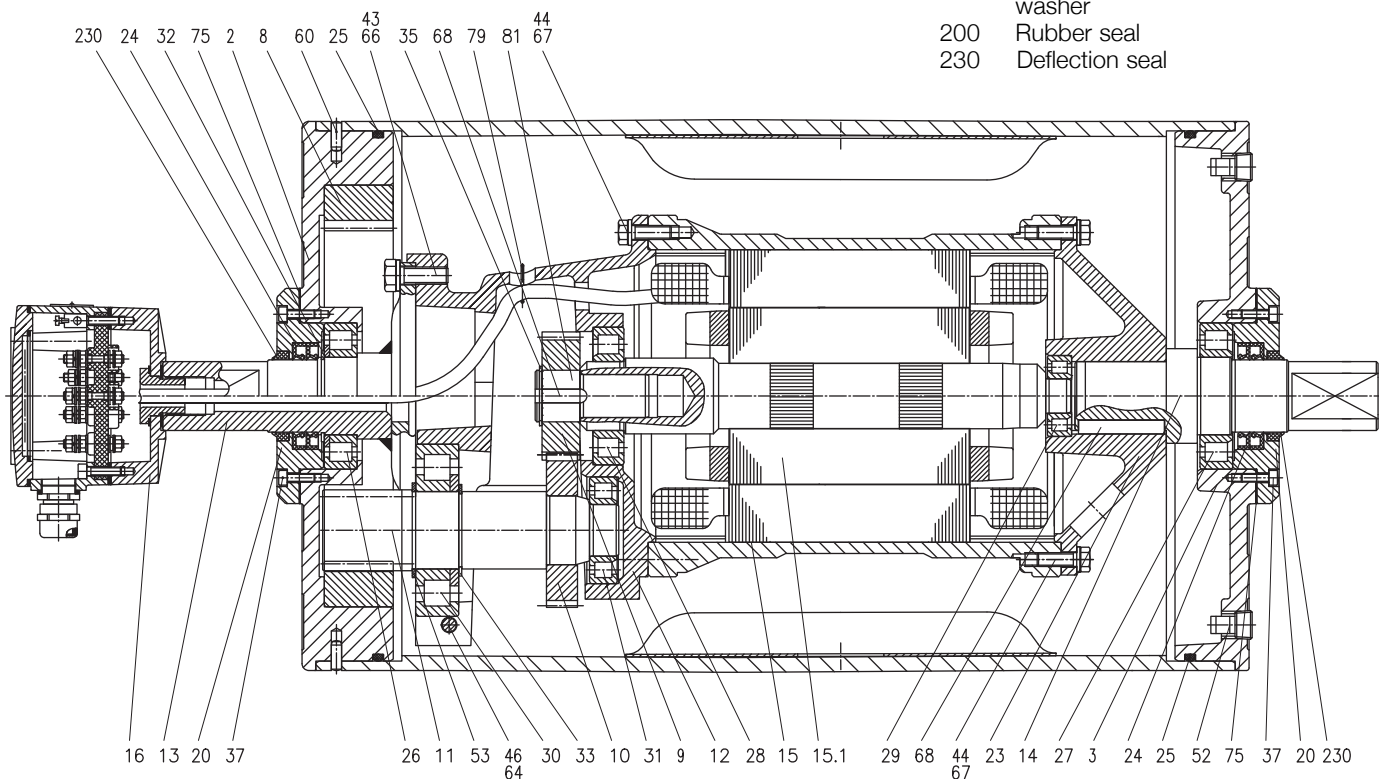

Pos. 52. sealed with plumber sealing tape



# Motorized Pulley 320H, Ø 320 mm

## Spare parts list and sectional drawings

Pos.	Description	Pos.	Description	Pos.	Description
1	Shell	90	Backstop	184	Bearing
2	End housing with geared rim	91	Electromagnetic brake	185	Bearing
3	End housing	93	Retaining ring	186	Key
8	Geared rim	94	Hexagon head screw	187	Key
9	Rotor pinion	95	Straight connector	188	Retaining ring
10	Input wheel	96	Elbow connector	189	Retaining ring
11	Output pinion	99	Waved spring washer	190	Retaining ring
12	Gear box	101	Key	191	Retaining ring
13	Front shaft	104	Distance washer	192	Retaining ring
14	Rear shaft	120	Labyrinth cover	193	Distance washer
15	Stator complete	121	Set screw	194	Set screw
15.1	Rotor	122	O-ring	195	Prevailing torque type hexagon nut
16	Terminal box complete	123	Grease nipple	196	Key
17	Nipple	143	O-ring	197	Retaining ring
20	Cover front side	146	Special compression washer	198	Distance ring
20.1	Cover with labyrinth groove	180	Intermediate pinion shaft	199	Bushing (inner race of the needle roller bearing)
21	Cover – rear side	181	Intermediate pinion	200	Rubber seal
21.1	Cover with labyrinth groove	182	Distance bushing	201	Hexagon head screw
23	Rear flange	183	Washer	230	Deflection seal
23.1	Rear flange for brake option				
24	2 Dust lip seals each side				
25	O-ring				
26	Bearing				
27	Bearing				
28	Bearing				
29	Bearing				
30	Bearing				
31	Bearing				
32	Retaining ring				
33	Retaining ring				
35	Retaining ring				
37	Hexagon socket screw				
38	Hexagon socket screw				
43	Hexagon socket screw				
44	Hexagon socket screw				
45	Hexagon socket screw				
52	Magnetic oil plug				
53.1	Compression nipple				
60	Parallel pin				
67	Toothed washer				
68	Key				
70	Toothed washer				
73	Set screw				
75	Gasket				
78	Gasket				
79	Holding clip or plastic tie				
80	Hexagon head screw				
84	Rear flange for brake				
85	Intermediate flange for backstop				
85.1	Intermediate flange for brake assembly				

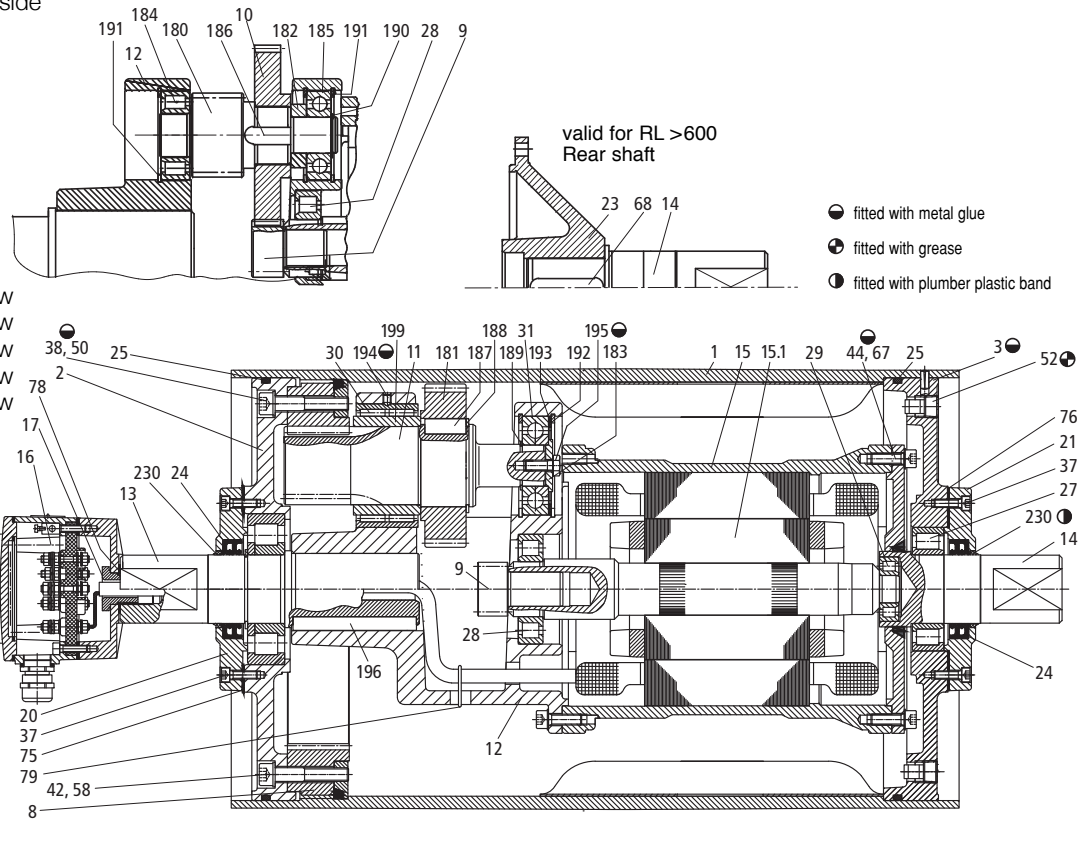



# Motorized Pulley 320L, 320M & 320H, Ø 320 mm

## Sectional drawings

Re-greasable Labyrinth Option

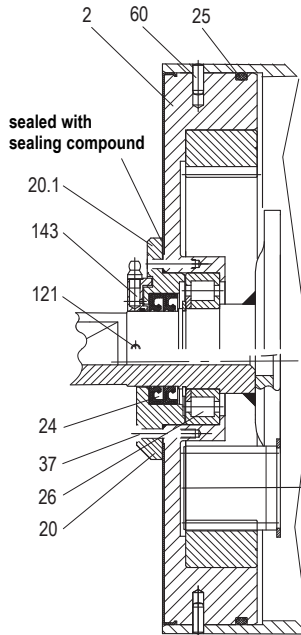
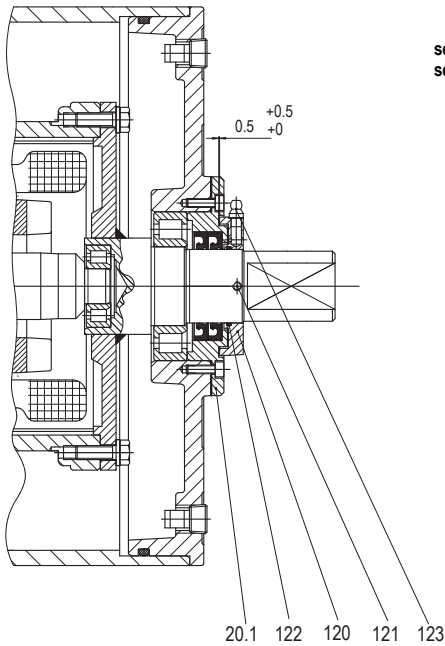

TS9N + TS11N  
Labyrinth Option  
valid for 320M

the pos. no. in brackets  
(21 & 21.1) is valid for  
320H 3-stage

TS10N + TS11N  
without labyrinth

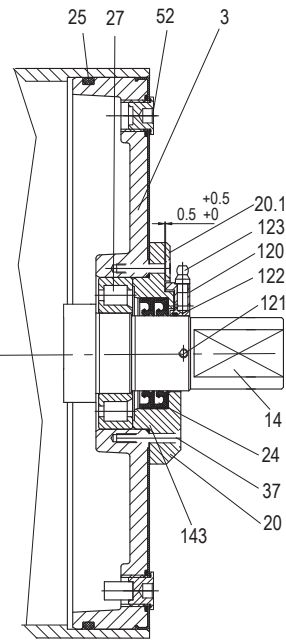

Stainless Steel Option

320L TS9N

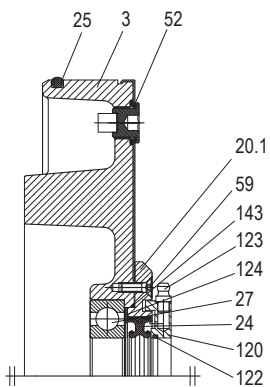

Elbow Connector

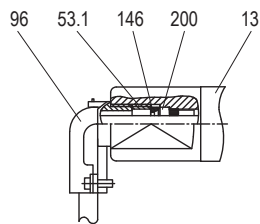

Straight Connector

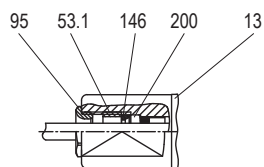

Electromagnetic Brake Option

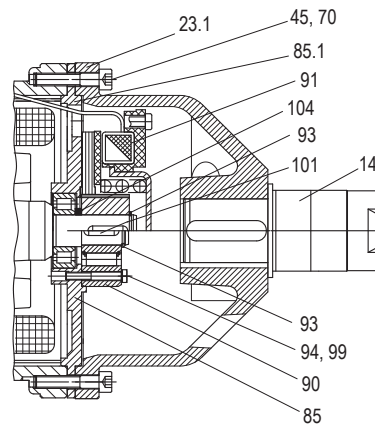

Backstop Option